

# WHITELINE

*Flat out*

## MUSTANG

Mustang 05-08 V8 coupe  
incl GT500 Shelby Cobra

# WADK

## WHITELINE ANTI DIVE KIT

From the creators of the infamous anti lift/caster kit for sports compacts comes the latest addition to the programme with the release of the WADK for FORD MUSTANG. The WADK replaces the front lower control arm rear bushing and provides:

Revised Anti-dive geometry to minimise suspension deflection under braking

Static Caster angle increased by 0.75 degree.

2 point caster adjustment

Low compliance polyurethane bush for minimum dynamic caster loss and positive steering feel.

Low rotational resistance.

High strength anodised aluminium mounts.



part # KCA305

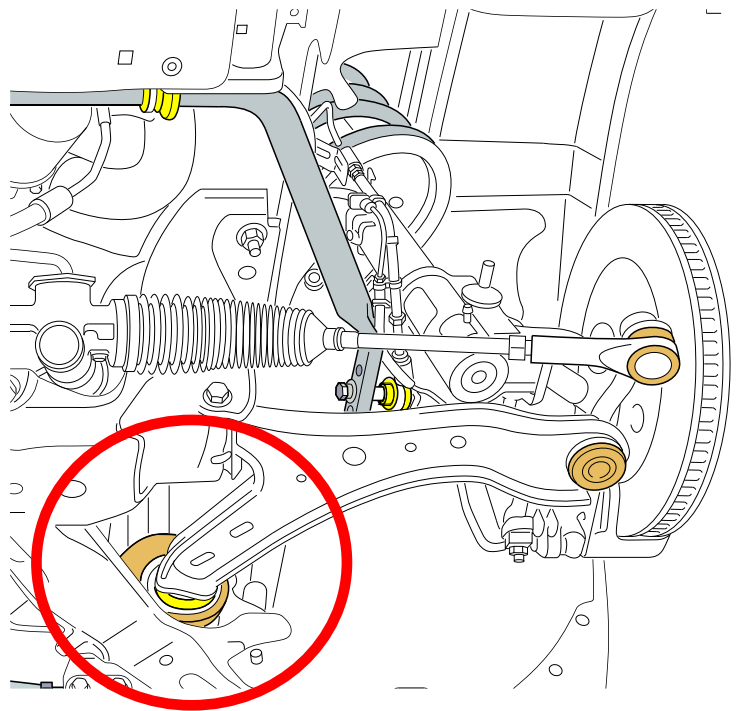

### Contents:

1. 12 x M6 x 10 Bolts
2. 4 x Offset caster washers
3. 1 x Alloy mount LH
4. 1 x Alloy mount RH
5. 6 x Exhaust heat shield brackets
6. 2 x Control arm tubes



Warning: Please drive carefully while you accustom yourself to the changed vehicle behaviour.

**Global**  
PERFORMANCE PARTS

4554 - 128th Ave. Holland, MI 49424  
Ph: 616 399 9025 Fax: 616 399 9174  
glenn@globalperformanceparts.com  
www.globalperformanceparts.com